

Data Sheet

DS-TMF-SLA5800-MFC-eng

March, 2008

Brooks® Digital MFC's & MFM's

Brooks® Models SLA5850, SLA5851, SLA5853 Mass Flow Controllers and Models SLA5860, SLA5861, SLA5863 Mass Flow Meters

GENERAL FEATURES

- Wide FS flow range for measurement and control of gases from <3 ccm to 2500 lpm (N₂ equivalent)
- Accuracy up to 1200 lpm: ±1.0% of rate (20%-100% FS) ±0.2% FS (below 20% FS)
1200-2500 lpm: ±1% FS including linearity.
(at calibration conditions).
- Industry leading sensor stability. Long term drift performance of < 0.2% per year. Increased system throughput by reducing maintenance and eliminating periodic recipe adjustment.
- Storage of up to 10 selectable calibration curves. Spares inventories are reduced by limiting the number of individual MFC/M's required, lowering inventory holding costs.
- Elastomer downport process connection option conforms to ANSI/ISA SP-76 standard to offer simplified installation and maintenance in an efficient footprint.

Control Response:

- Settling Time of less than 1 second.
(better on request).
- Soft start can be used to tailor MFC performance to process requirements.
- Proprietary Adaptive Valve Control algorithm is available which assures that unexpected variations in process pressure do not cause flow to deviate from setpoint.

Analog I/O Option:

- 15-pin D-Connector
- 0(1)-5 Volt or 0(4)-20 mA setpoint and flow signals
- Single sided 24 Volt DC power supply
(13.5-27 volts DC range).
- Separate Valve-Override signal
- Precision 5 Volt Reference Output signal
- Compatible with Brooks' Model 0150 series secondary electronics
- TTL (open collector) Alarm Output signal

Digital Communication Options:

- DeviceNet™, ODVA™ certified
- FOUNDATION™ Fieldbus, H1 Certified
- HART® based RS-485 multidrop



Brooks® Digital MFC's & MFM's

DESCRIPTION

Brooks Instrument's SLA5800 Series is an elastomer sealed digital thermal mass flow measurement and control instrument, which offers unparalleled flexibility and performance. The SLA5800 Series MFC is designed for use in advanced gas handling systems. The result is the most accurate, repeatable, and responsive MFC on the market today!

Wide Flow Range

The SLA5800 Series covers an extremely broad range of flowrates. Model SLA5850 can have a full scale flow as low as 3 ccm. With a high turndown ratio of 50:1, accurate gas flow can be measured or controlled down to 0.06 ccm! Model SLA5853 can meter or control gas flow up to 2500 lpm.

Fast Response Performance

The all-digital electronics and superior mechanical configuration in the SLA5800 series provide for ultra fast response characteristics. Settling times are specified as less than one second, but Brooks' Adaptive Valve Control can achieve response times of 0.2 sec.

Broad Array of Communication Options

Brooks® offers traditional 0-5 volt and 4-20mA analog options as well as RS-485 digital communications ("S-protocol", based on HART). Brooks also offers control interface via digital network protocols like DeviceNet, a high-speed (up to 500k baud) digital communication network, or FOUNDATION® Fieldbus. Brooks' communication capabilities and device-profiles have been certified by the ODVA (Open DeviceNet Vendor's Association) and the ITK Interoperability Test Kit. Other network protocols are in development. Talk to your Brooks representative about your specific needs.

Reduced Cost of Ownership

The SLA5800 Series allows multi-gas and multi-range capabilities to reduce customer inventory. Storage and pre-programming of up to 10 gas calibrations easily permits users to switch between different gases and ranges on a single device.

Coplanar Valve Option

The coplanar valve option offers unmatched performance. Due to its simplified construction, the valve exhibits superior turndown, repeatability, stability and response time.

SPECIFICATIONS

PERFORMANCE CHARACTERISTICS:

Flow Ranges

Models SLA5850/SLA5860

Any FS range from 0-3 ccm to 0-30 lpm (N₂ eq.)

*Up to 0-50 lpm (N₂ eq.) w/coplanar valve option

Models SLA5851/SLA5861

Any FS range from 20-100 lpm (N₂ eq.)

Up to 200 lpm H₂ flows possible

Models SLA5853/SLA5863

Any FS range from 100-2500 lpm (N₂ eq.).

Control Range

Turndown 50:1

Turndown 100:1 with Coplanar valve option

(For any FS range from 1-50 lpm (N₂ eq.))

Accuracy (N₂ eq. at calibration conditions).

±1.0% of rate (20% - 100% FS)

±0.2% FS (below 20% FS) up to 1100 lpm.

(Optional: ±0.7% of rate ±0.2% FS ("S-Series") up to 1100 lpm.

Flow ranges above 1100 lpm and up to 2500 lpm:

±1.0% of full scale.

Repeatability

±0.20% of rate.

Settling Time/Response Time

< 1 second to within ±2% FS of final value for a

0-100% command step (better on request)

for flow rates up to 100 lpm (N₂ eq.).

< 3 seconds to within ±2% FS of final value for a

0-100% command step (better on request)

for flow rates greater than 100 lpm (N₂ eq.) up to 2500 lpm (N₂ eq.).

Sensitivity to Mounting Attitude

<0.2% FS maximum deviation from specified accuracy, after rezeroing.

RATINGS:

Temperature Sensitivity

Zero: less than 0.05% FS per °C

Span: less than 0.05% FS per °C

Table 1 Flow Ranges and Pressure Ratings

Mass Flow Controller	Mass Flow Meter	Flow Ranges N ₂ eq. Ratings		Pressure Unit	PED Module H category
Model:	Model:	Min. F.S.	Max. F.S.	Bar/PSI	
SLA5850 ⁽¹⁾	SLA5860 ⁽¹⁾	0.003	30 lpm ⁽⁴⁾	100 Bar/1500 PSI	SEP
SLA5851	SLA5861 ⁽¹⁾	20	100 lpm	100 Bar/1500 PSI ⁽³⁾	SEP
SLA5853 ⁽²⁾	SLA5863	100	2500 lpm	70 bar/1000 PSI	1 for all 150 lb Flanges 2 for all other connections

(1) 300 bar (4500 psi) version optional. (2) Max. Delta P for 5853 is 20 bar (300 psi).

(3) 70 bar / 1000 psi for UL Certification. (4) 50 lpm w/coplanar valve option

Data Sheet

DS-TMF-SLA5800-MFC-eng
March, 2008

Brooks® Digital MFC's & MFM's

Pressure Sensitivity

± 0.03% per psi up to 200 psig (N₂ eq.).

Maximum Operating Pressure

See Table 1 below:

Optional 4500 psig (300 bar) For 50,60 & 61 series body only.

Pressure Differential Range (Controllers)

Minimum:

Model SLA5850

5 psi (0.35 bar) up to 30 lpm (N₂ eq.)

30 psi (2.07 bar) from 30 lpm to 50 lpm (N₂ eq.)
with coplanar valve option

Model SLA5851

10 psi (0.69 bar) from 30 lpm to 100 lpm (N₂ eq.)

Model SLA5853

7.5 psi (0.52 bar) at 500 lpm (N₂ eq.)

14.5 psi (1.00 bar) at 1000 lpm (N₂ eq.)

35.0 psi (2.41 bar) at 2500 lpm (N₂ eq.)

High DP valve 30 psi (2.07 bar) to 290 psi (20 bar max.)

Low DP valve 7.5 (0.52 bar) to 30 psi (2.07 bar max.)

Maximum:

Model SLA5850 with coplanar valve 250 psi (17-24 bar)

Minimum and maximum pressure drop depends on gas and FS flow rate (consult factory)..

Leak Integrity

Inboard to Outboard: 1x10⁻⁹ atm scc/sec Helium max.

Ambient Temperature Limits

Operating: 0°C to 65°C (32°F to 149°F)

Non-Operating: -25°C to 100°C (-13°F to 212°F)

Fluid Temperature Limits

0°C to 65°C (32°F to 149°F)

PHYSICAL:

Materials of Construction

Wetted parts - stainless steel with

Viton® fluoroelastomers

Optional: Buna-N, Kalrez®, Teflon®/Kalrez and EPDM

Outline Dimensions

Refer to Outline Drawings Figures 1 through 9

Process Connections

Refer to Outline Drawings Figures 1 through 9

ELECTRICAL CHARACTERISTICS:

Electrical Connections

Analog/RS-485 version: 15-pin D-Connector, male

Digital I/O:

DeviceNet: 5-pin Micro-Connector, male

FOUNDATION Fieldbus: 4-pin Micro-Connector, male

Power Supply Voltage

Analog option: 13.5-27 Vdc,

Digital I/O:

DeviceNet I/O: 11-25 Vdc

FOUNDATION Fieldbus I/O: 14-27 Vdc

SLA5851S Model: 22-27 Vdc

Power Requirements	Watts, typical	Watts, max.
Analog I/O option, no valve:	1.6	1.8
Analog I/O option, with valve:	3.6	4.0
Digital I/O DeviceNet option, n.v.:	3.6	4.0
Digital I/O DeviceNet option, w.v.:	6.9	7.6

Certifications:

EMC Directive 89/336/EEC:

Per EN 61326

Hazardous Location Classification

Enclosure Type 1/IP40

Ambient Temperature: 0°F ≥ Tamb ≤ 150°F

(0°C ≥ Tamb ≤ 65°C)

United States and Canada

UL Recognized: E73889 Volume 3, Section 4



Non-Incendive,
Class 1, Division 2
Groups A, B, C & D; T4

Per UL 1604 and CSA-213

Class I, Zone 2, AEx nA II T4

Per ANSI/ISA 12.12.02 - 2003 and ANSI/UL 60079-15

Ex nA II T4

Per CSA - E79 - 15

Europe - ATEX Directive 94/9/EC

KEMA 04ATEX1118X



II 3 G EEx nA II T4



(SL58xxS Only)

Per EN 50021

Pressure Equipment Directive (97/23/EC)

See pressure Table 1 for further information

Brooks® Digital MFC's & MFM's

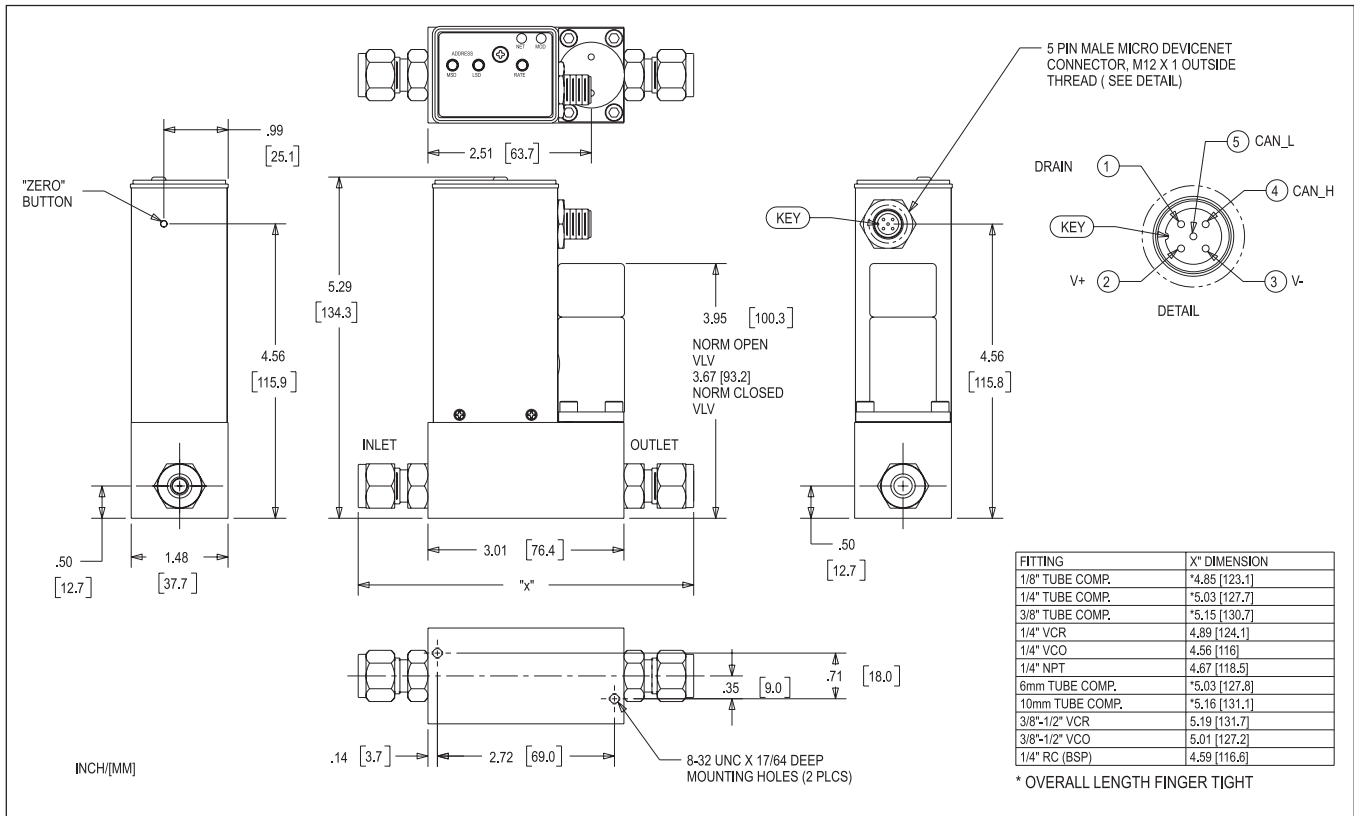

Figure 1 Model SLA5850D Digital I/O DeviceNet MFC

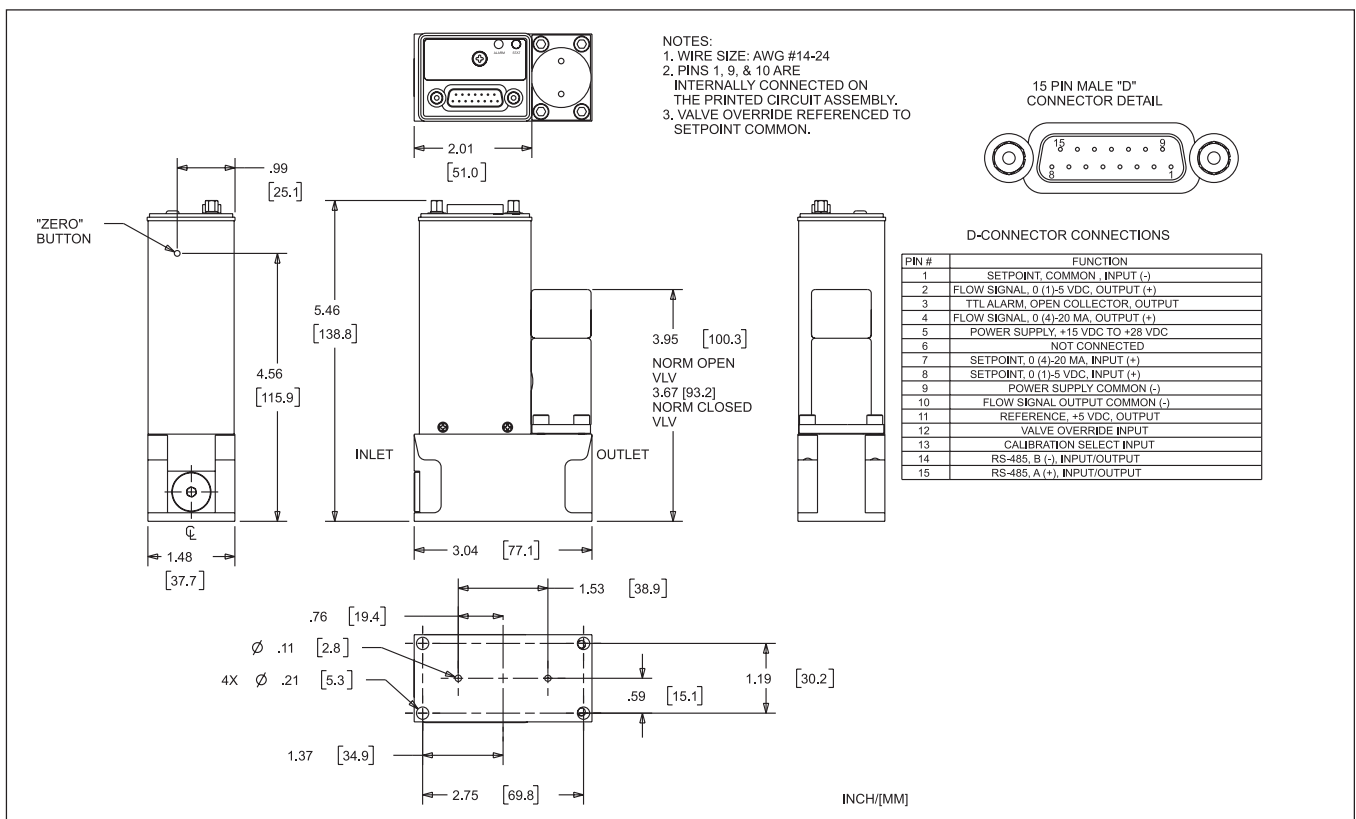

Figure 2 Model SLA5850S Analog I/O MFC with RS-485 Elastomer Downport Connections

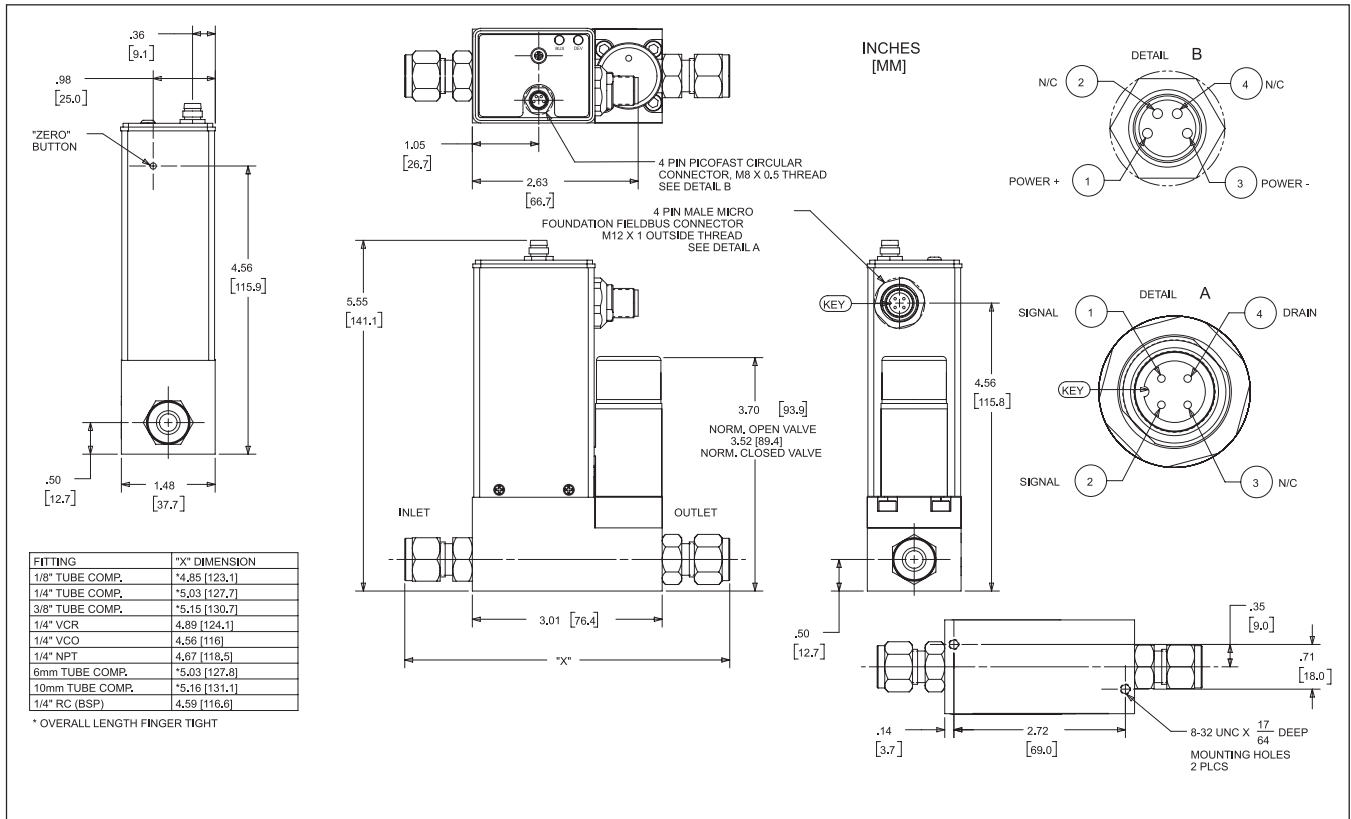

Figure 3 Model SLA5850F Digital I/O FOUNDATION Fieldbus MFC with Coplanar Valve

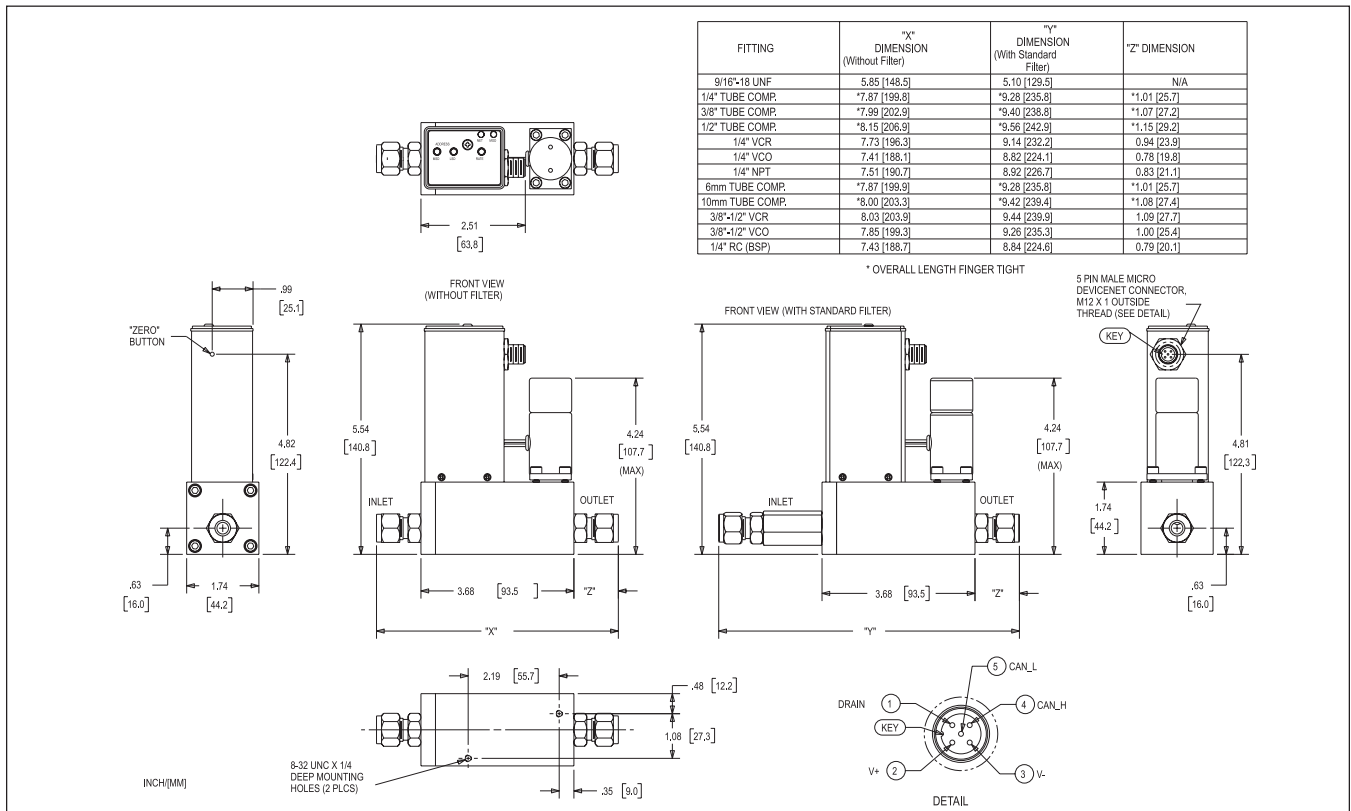

Figure 4 Model SLA5851D Digital I/O DeviceNet MFC

Brooks® Digital MFC's & MFM's

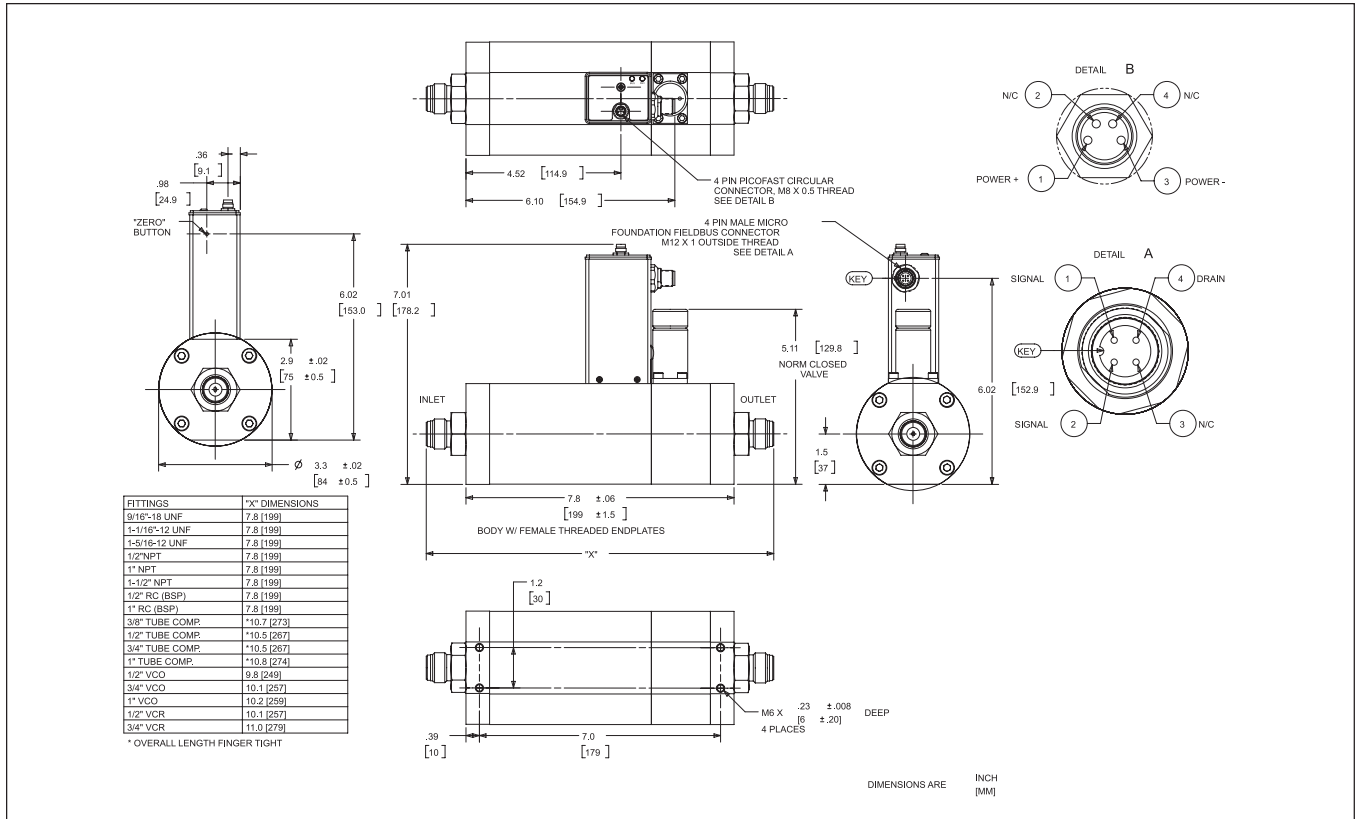

Figure 5 Model SLA5853F Digital I/O FOUNDATION Fieldbus MFC

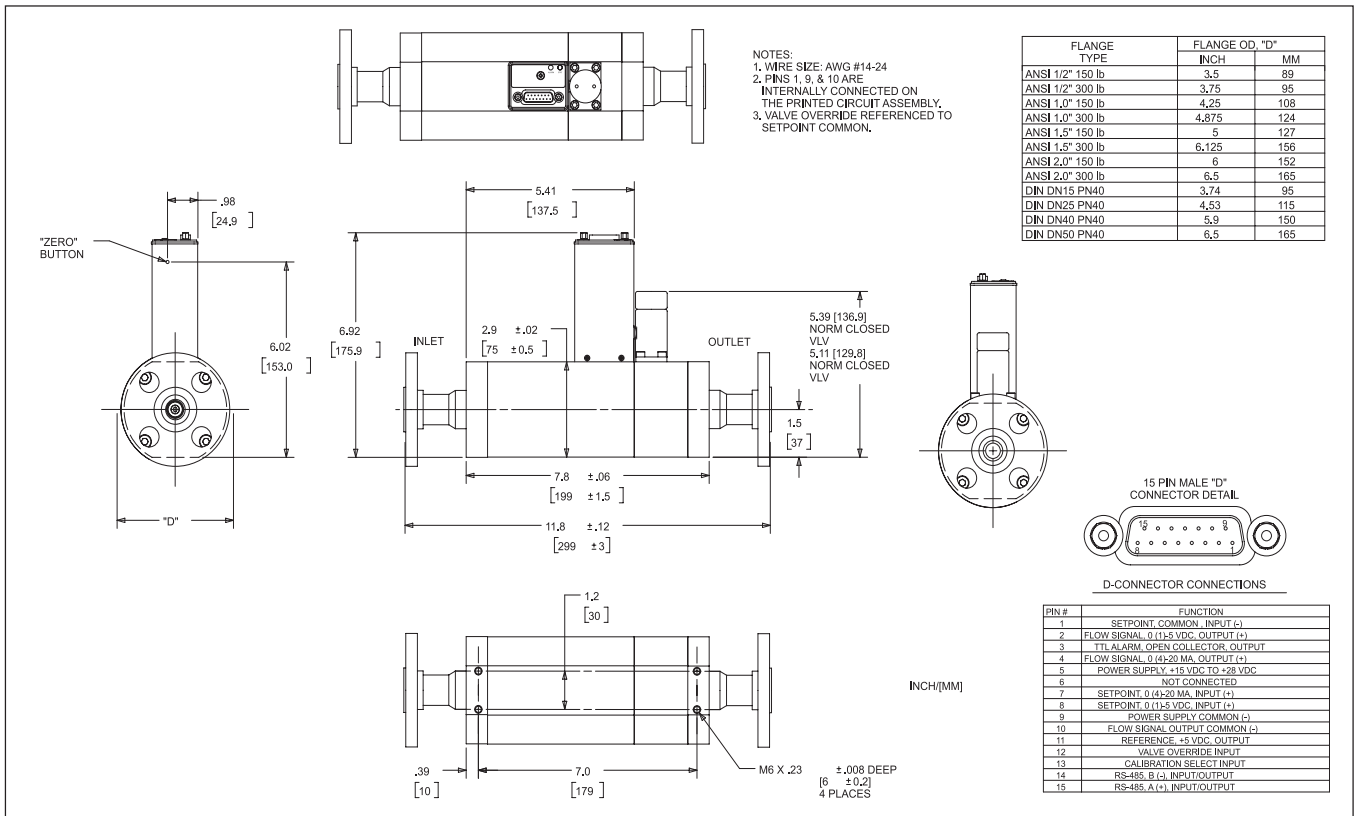

Figure 6 Model SLA5853S Analog I/O MFC with Flanged Connections

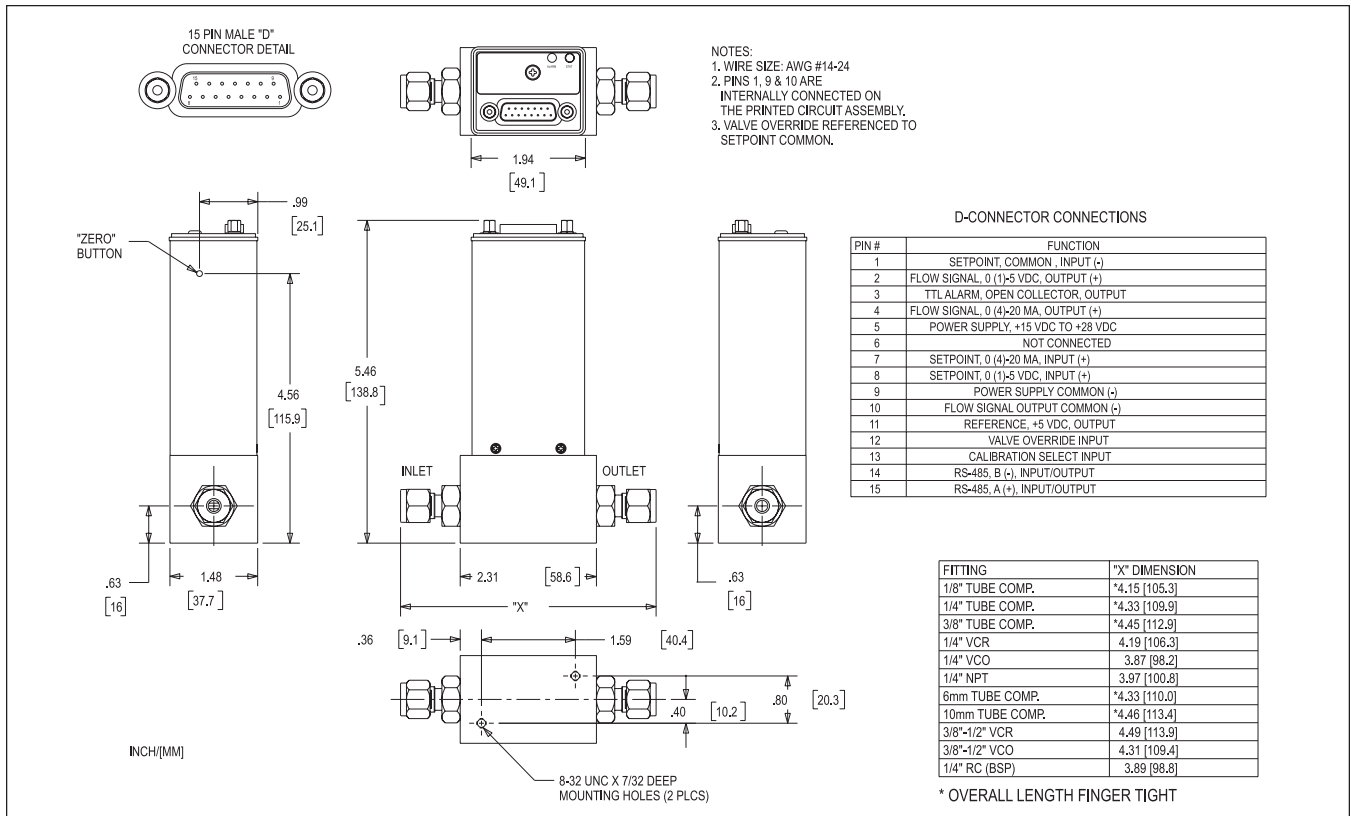

Figure 7 Model SLA5860S Analog I/O MFM with RS-485

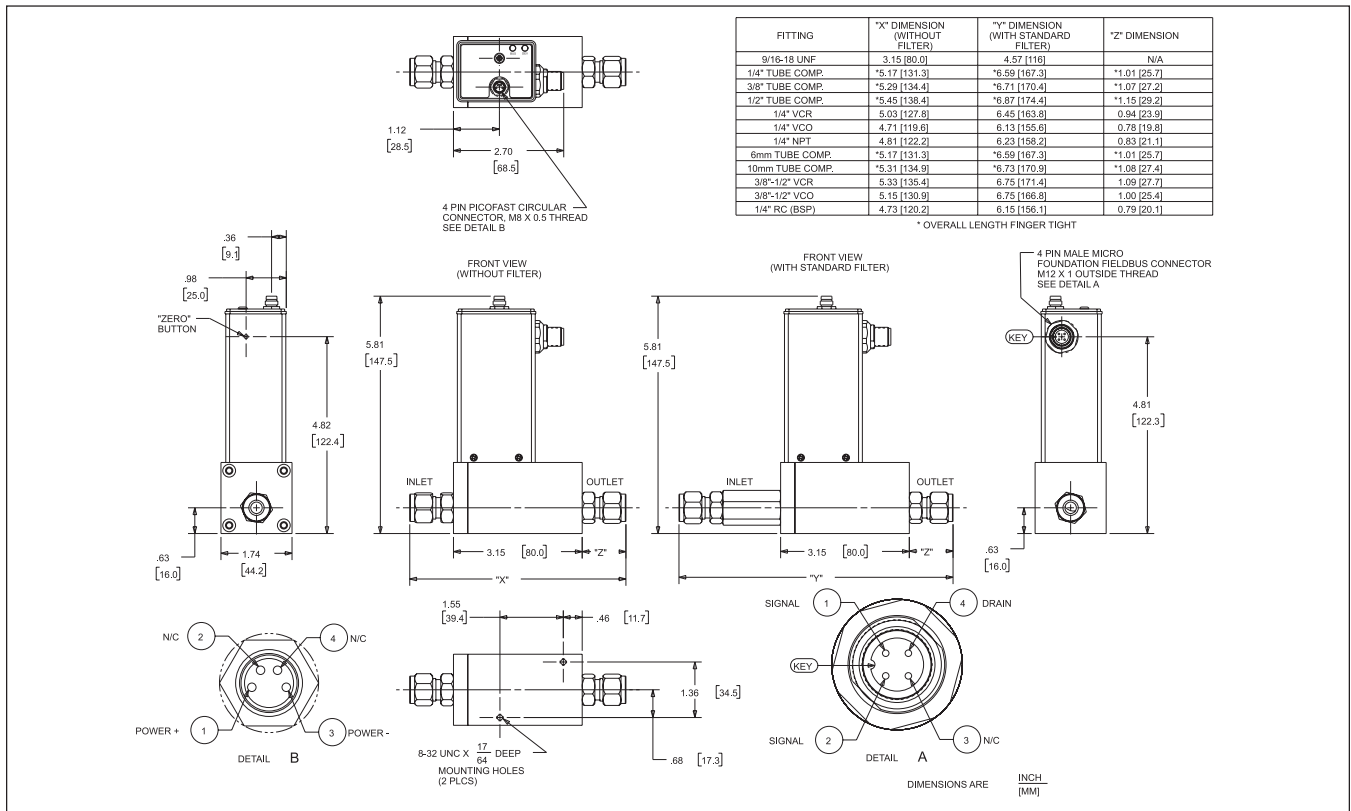

Figure 8 Model SLA5861F Digital I/O FOUNDATION Fieldbus MFM

Brooks® Digital MFC's & MFM's

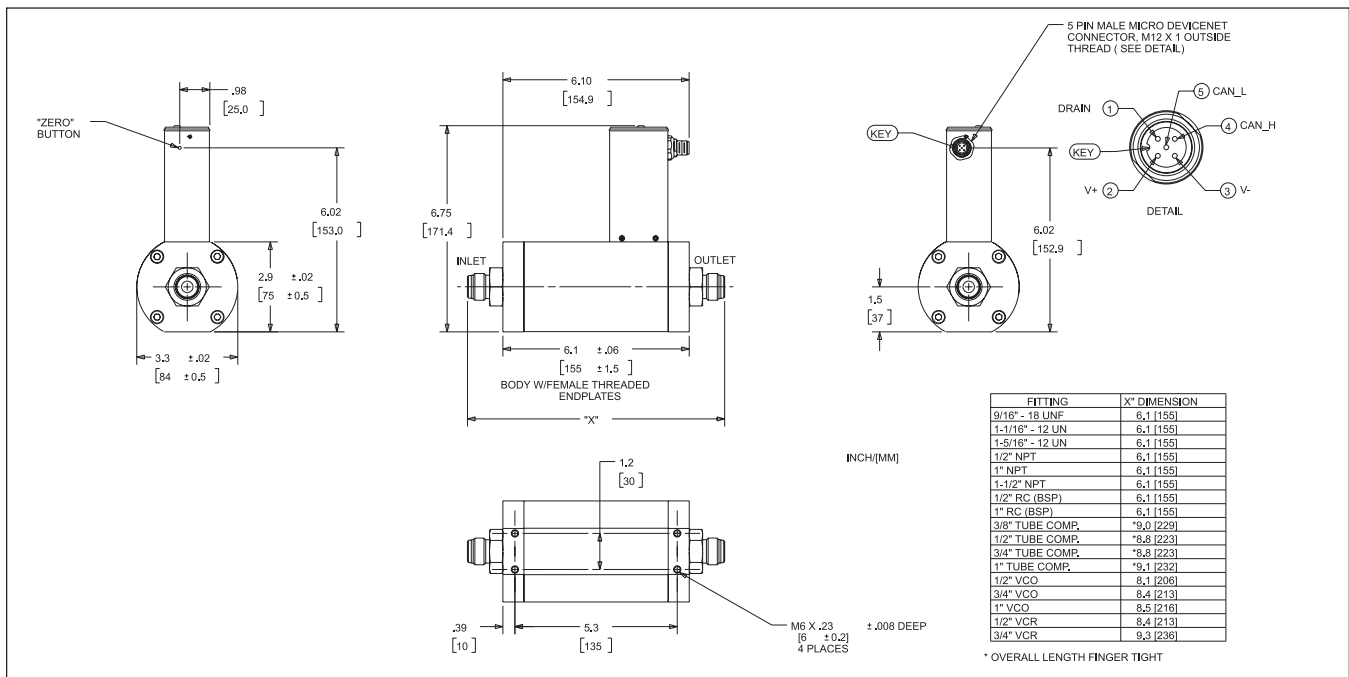

Figure 9 Model SLA5863D Digital I/O DeviceNet MFM

BROOKS LOCAL AND WORLDWIDE SUPPORT

- Brooks Instrument provides sales and service facilities around the world.
- Calibration facilities are available in locally based sales and service offices. Certified by our local Weights and Measures Authorities and traceable to the relevant international standards.

START-UP SERVICE AND IN-SITU CALIBRATION

- Brooks Instrument can provide start-up service prior to operation when required, if necessary under in-situ conditions, and the results will be traceable to the relevant international quality standards.

CUSTOMER SEMINARS AND TRAINING

- Brooks® can provide customer seminars and dedicated training to engineers, end users and maintenance persons.

HELP DESK

In case you need technical assistance:

Americas ☎ 1-888-554-FLOW
 Europe ☎ +(31)-318-549-290 Within Netherlands ☎ 0318-549-290
 Asia ☎ +011-81-3-5633-7100

Due to Brooks Instrument's commitment to continuous improvement of our products, all specifications are subject to change without notice.

PC-based Support Tools See Instruction Manual X-TMF-SLA5800-MFC-eng for more information.



TRADEMARKS

Brooks	Brooks Instrument, LLC	Kalrez	DuPont Dow Elastomers
DeviceNet	Open DeviceNet Vendors Association, Inc.	ODVA	Open DeviceNet Vendors Association, Inc.
FOUNDATION Fieldbus	Fieldbus FOUNDATION	Teflon	E.I. DuPont de Nemours & Co.
HART	HART Communications Foundation	VCO	Cajon Co.
ITK	Fieldbus FOUNDATION	VCR	Cajon Co.
		Viton	DuPont Performance Elastomers

Brooks Instrument
 407 West Vine Street
 P.O. Box 903
 Hatfield, PA 19440-0903 USA
 T (215) 362-3700
 F (215) 362-3745
 E-Mail BrooksAm@EmersonProcess.com
www.BrooksInstrument.com

Brooks Instrument
 Neonstraat 3
 6718 WX Ede, Netherlands
 T 31-318-549-300
 F 31-318-549-309
 E-Mail BrooksEu@EmersonProcess.com

Brooks Instrument
 1-4-4 Kitasuna Koto-Ku
 Tokyo, 136-0073 Japan
 T 011-81-3-5633-7100
 F 011-81-3-5633-7101
 E-Mail BrooksAs@EmersonProcess.com